

The kinetic analysis of non-isothermal data

Jiří Málek

Joint Laboratory of Solid State Chemistry of the Czech Academy of Sciences and the University of Chemical Technology, Čs. Legií sq. 565, 532 10 Pardubice (Czech and Slovak Federal Rep.)

(Received 22 January 1992)

Abstract

The correlation of kinetic parameters and the apparent kinetic models is discussed with respect to the reliability of kinetic information obtained from thermal analysis (TA) data.

A simple method of kinetic analysis of TA data is described. The method allows one to find the appropriate model characterizing the process studied as well as the calculation of the kinetic parameters. This method was used to develop a new kinetic software package TA-system.

LIST OF SYMBOLS

a, b	constants in eqn. (2)
A	pre-exponential factor in eqn. (1) (s^{-1})
E	activation energy (kJ mol^{-1})
$f(\alpha)$	general expression of kinetic model
$f'(\alpha)$	differential form of kinetic model ($df(\alpha)/d\alpha$)
$g(\alpha)$	integral form of kinetic model ($\int d\alpha/f(\alpha)$)
m, n	kinetic exponents
p	kinetic exponent ratio (m/n)
q	apparent activation energy ratio (E_{app}/E)
R	universal gas constant ($8.314 \text{ J mol}^{-1} \text{ K}^{-1}$)
t	time (s)
T	absolute temperature (K)
x	reduced activation energy (E/RT)
$y(\alpha)$	function defined by eqn. (6)
$z(\alpha)$	function defined by eqn. (7)

Correspondence to: J. Málek, Joint Laboratory of Solid State Chemistry of the Czech Academy of Sciences and the University of Chemical Technology, Čs. Legií sq. 565, 532 10 Pardubice, Czech and Slovak Federal Rep.

Greek Letters

α	degree of conversion (dimensionless)
β	heating rate (K min^{-1})
$\pi(x)$	expression of temperature integral, eqn. (A2)

Subscripts and superscripts

app	apparent kinetic model
p	maximum of TA curve
M	maxima of $y(\alpha)$ and $f(\alpha)$ functions
∞	parameter related to infinite x

INTRODUCTION

The extraction of the maximum relevant information from non-isothermal data obtained by thermal analysis (TA) techniques and the modelling of the kinetic process are common tasks in TA data treatment. Nevertheless, the problem of the validity and applicability of mathematical models in kinetic analysis of TA data is still considered a very controversial topic. Apart from the question of the physical meaning of the kinetic parameters (which has not been answered until now) there are several problems inherent in the mathematical formalism used for the description of kinetic processes. The aim of this paper is to discuss the possibilities and limitations of the kinetic analysis of non-isothermal data.

In the following section we first review briefly the mathematical relationship used to describe TA data. A subsequent section presents some consequences of the mutual correlation of kinetic parameters and their implications for a reliable kinetic analysis. Finally, a completely new method of kinetic analysis is outlined which eliminates the effect of experimental conditions. The method allows the determination of the most suitable kinetic model and calculation of a complete set of kinetic parameters.

THE KINETIC EQUATION

Most reactions studied by TA techniques can be described by the equation

$$d\alpha/dt = A e^{-x} f(\alpha) \quad (1)$$

where $x = E/RT$ is the reduced activation energy. The function $f(\alpha)$ represents the mathematical expression of the kinetic model. The most frequently cited basic kinetic models are summarized in Table 1.

TABLE 1

The basic kinetic models

Models	Symbol	$f(\alpha)$
Johnson–Mehl–Avrami	JMA(n)	$n(1-\alpha)[- \ln(1-\alpha)]^{1-1/n}$
2D-reaction	R2	$(1-\alpha)^{1/2}$
3D-reaction	R3	$(1-\alpha)^{1/3}$
2D-diffusion	D2	$1/[- \ln(1-\alpha)]$
Jander eqn.	D3	$3/2(1-\alpha)^{2/3}/[1-(1-\alpha)^{2/3}]$
Ginstling–Brounshtein	D4	$3/2[(1-\alpha)^{-1/3}-1]$

The exponent n in the Johnson–Mehl–Avrami equation depends on the mechanism of the nucleation-growth process. In most cases which have been studied, the exponent n remains constant through the greater part of the reaction [1].

In addition to the basic kinetic models which correspond to a certain geometry of the reaction interface, there are also empirical kinetic models (Table 2). The kinetic exponent n can be an integer or a fraction for both the RO(n) and SB(m, n) models. It is evident that the RO(n) model includes both R2 and R3 models for $n = 1/2$ and $n = 2/3$ respectively. It was recently shown [2] that acceptable values of the parameter m for the SB(m, n) model are confined to the interval $0 < m < 1$.

The aim of the kinetic analysis of TA data is to find the most probable kinetic model which gives the best description of the studied process and allows the calculation of reliable values for the parameters E and A .

THE CORRELATION OF KINETIC PARAMETERS

Both the activation energy and the pre-exponential factor in eqn. (1) are mutually correlated. This correlation can be expressed by the following equation (see Appendix):

$$\ln A = a + bE \quad (2)$$

where a and b are constants. Any change in the activation energy is therefore “compensated” by the change in $\ln A$ as expressed by eqn. (2). From this point of view, it seems that the methods of kinetic analysis which

TABLE 2

The empirical kinetic models

Model	Symbol	$f(\alpha)$
Reaction order	RO(n)	$(1-\alpha)^n$
Šesták–Berggren	SB(m, n)	$\alpha^m(1-\alpha)^n$

TABLE 3

The value of parameters n_{app}^{∞} and q_{RO}^{∞} for $x_p \rightarrow \infty$

Model	n_{app}^{∞}	q_{RO}^{∞}
JMA(n)	1	n
D2	0.269	0.483
D3	0.666	0.5
D4	0.420	0.495

attempt to determine all the kinetic parameters from only one experimental TA curve are somewhat problematic. We have to realize that this problem cannot be solved, even using the most sophisticated non-linear regression algorithms, unless there is a priori knowledge of the kinetic model or at least one kinetic parameter.

THE APPARENT KINETIC MODEL

As a consequence of the mutual correlation of the kinetic parameters E and A , any TA curve can be described by an apparent kinetic model, instead of by the appropriate one, for a certain value of apparent activation energy E_{app} . For example it can be shown [3] that a TA curve can be described by the RO(n_{app}) model for the apparent activation energy $E_{\text{app}} = q_{\text{RO}} E$, where E is the true activation energy. The multiplicative factor q_{RO} is characteristic for the true kinetic model. Table 3 shows the value of the parameters n_{app}^{∞} and q_{RO}^{∞} for infinite x_p . The parameter q_{RO} is not constant and decreases slightly with decreasing x_p for diffusion models (D2, D3 and D4). However, this parameter increases with decreasing x_p for the JMA(n) model in accordance with the equation

$$q_{\text{RO}} = \frac{n - 1}{x_p \pi(x_p)} + 1 \quad (3)$$

where $\pi(x_p)$ is an approximation of the temperature integral (see Appendix). We would like to point out that the relation reported by Criado et al. [4], $E_{\text{app}} = (1.05n - 0.05)E$, corresponds to eqn. (3) for $x_p = 38.3$.

Similarly, any TA data can be described by the SB(m_{app} , n_{app}) model, instead of by the appropriate one, for an apparent activation energy given by $E_{\text{app}} = q_{\text{SB}} E$. The multiplicative factor is always lower than for the RO(n_{app}) model, i.e. $q_{\text{SB}} < q_{\text{RO}}$, and it can be calculated using eqn. (3):

$$q_{\text{SB}} = \frac{f(\alpha_p)}{f'(\alpha_p)} \left(\frac{m_{\text{app}}}{\alpha_p} - \frac{n_{\text{app}}}{1 - \alpha_p} \right) \quad (4)$$

Thus any basic kinetic model shown in Table 1 can be described by the apparent kinetic exponents m_{app} and n_{app} for $E_{\text{app}} \leq q_{\text{RO}} E$. Equation (4)

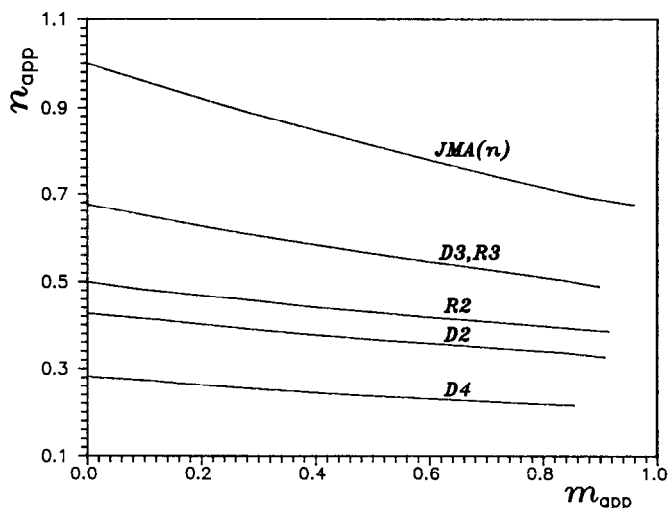

Fig. 1. Apparent kinetic exponents of the $SB(m_{app}, n_{app})$ model corresponding to the D2, D3, D4, R2, R3 and $JMA(n)$ kinetic models.

implies interdependence of the apparent kinetic exponents as shown in Fig. 1. An important feature of the m_{app} vs. n_{app} plot is that it is characteristic for the true kinetic model. Nevertheless, these plots are identical for the D3 and R3 models.

It is clear that any TA curve can be interpreted within the scope of several kinetic models by simply varying the apparent activation energy. Therefore it can hardly be fruitful to analyse only one TA curve without any complementary information about the kinetic process.

THE KINETIC ANALYSIS

The correlation of kinetic parameters and the apparent kinetic models does not allow the correct kinetic analysis to be performed by using only one experimental TA curve. This problem can be solved, however, if the true activation energy is known. Then the most probable kinetic model can be determined and the pre-exponential term is calculated subsequently. The method of kinetic analysis is described in the following sections.

Calculation of the activation energy

The calculation of the activation energy is based on multiple-scan methods where several measurements at different heating rates are needed. Probably the most popular of these is the Kissinger method [5] based on the equation derived from the condition for the maximum rate on a TA

curve. A very similar method of calculation of activation energy is the Ozawa method [6].

An alternative method of calculation of the activation energy is the isoconversional method, which follows from the logarithmic form of the kinetic equation, eqn. (1):

$$\ln(d\alpha/dt) = \ln[Af(\alpha)] - E/RT \quad (5)$$

The slope of $\ln(d\alpha/dt)$ versus $1/T$ for the same value of α gives the value of the activation energy. This procedure can be repeated for various values of α . Thus the method readily provides a check for the invariance of E with respect to α , which is one of the basic assumptions in kinetic analysis. Hence the isoconversional method can be recommended for the calculation of E .

However, we cannot recommend the Freeman–Carroll method [7] because it was derived for the RO(n) model and, therefore, owing to the mutual correlation of kinetic parameters, this method always gives apparent kinetic parameters n_{app} and E_{app} corresponding to the RO(n_{app}) model, regardless of the true kinetic model.

Determination of the kinetic model

Once the activation energy has been determined, it is possible to find the kinetic model which best describes the measured set of TA data. It can be shown that for this purpose it is useful to define two special functions $y(\alpha)$ and $z(\alpha)$, which can easily be obtained by simple transformation of experimental data. These functions can be expressed as follows [8,9]:

$$y(\alpha) = (d\alpha/dt) e^x \quad (6)$$

$$z(\alpha) = \pi(x)(d\alpha/dt)T/\beta \quad (7)$$

The $y(\alpha)$ function is proportional to the $f(\alpha)$ function. Thus by plotting the $y(\alpha)$ dependence, normalized within the $(0, 1)$ interval, the shape of the function $f(\alpha)$ is obtained. The $y(\alpha)$ function is therefore characteristic for a given kinetic model, as shown in Fig. 2, and it can be used as a diagnostic tool for kinetic model determination. The mathematical properties of the $y(\alpha)$ function for the basic kinetic models are summarized in Table 4. The $y(\alpha)$ function has a maximum $\alpha_M \in (0, \alpha_p)$ both for the JMA($n > 1$) and SB(m, n) models (see Appendix eqns. (A13) and (A14)).

It should be stressed that the shape of the $y(\alpha)$ function is strongly influenced by E . Hence the true activation energy is vital for a reliable determination of the kinetic model because of the correlation of the kinetic parameters.

We can discuss the mathematical properties of the $z(\alpha)$ function in a similar manner. It is fairly easy to demonstrate (see Appendix eqn. (A10)) that the $z(\alpha)$ function has a maximum at α_p^∞ for all the kinetic models

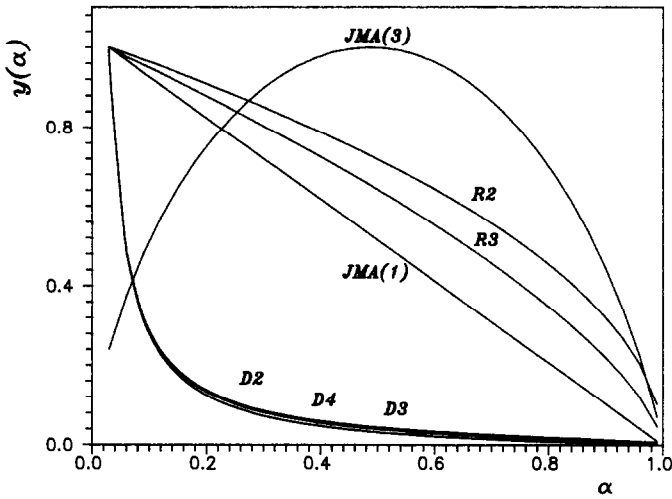

Fig. 2. Typical shapes of the $y(\alpha)$ function for several kinetic models.

summarized in Tables 1 and 2. This parameter has characteristic values [8] for the basic kinetic models as summarized in Table 5. It is interesting that the α_p^∞ value is practically independent of the value of the activation energy

TABLE 4

Properties of the $y(\alpha)$ function for the basic kinetic models

Model	$y(\alpha)$
$JMA(n)$	Concave for $n < 1$, linear for $n = 1$, maximum for $n > 1$
R2	Convex
R3	Convex
D2	Concave
D3	Concave
D4	Concave

TABLE 5

The values of the parameter α_p^∞

Model	α_p^∞
$JMA(n)$	0.632
R2	0.750
R3	0.704
D2	0.834
D3	0.704
D4	0.776

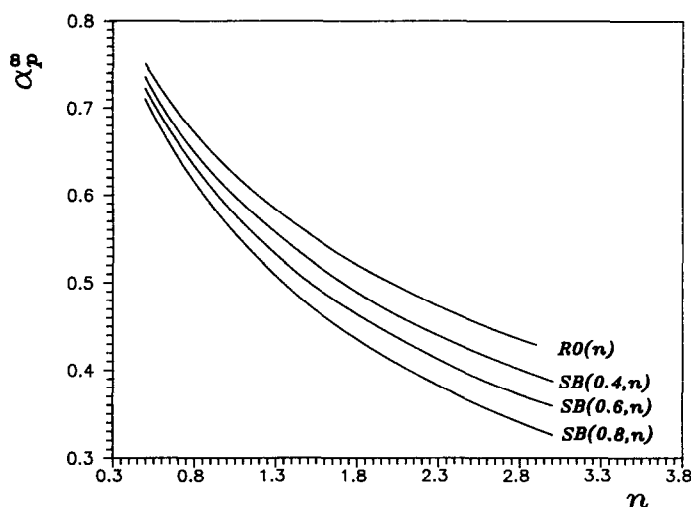

Fig. 3. The dependence of the maximum of the $z(\alpha)$ function α_p^∞ on the kinetic exponent n for the $RO(n)$ and $SB(m, n)$ kinetic models.

used to calculate the $z(\alpha)$ function (in fact, it varies within 1% of the theoretical value). An important fact is that the α_p^∞ value is invariant with respect to the kinetic exponent for the $JMA(n)$ model. However, for both the $RO(n)$ and $SB(m, n)$ models, the parameter α_p^∞ depends on the values of the kinetic exponents as shown in Fig. 3.

It is evident that the shape of the $y(\alpha)$ function, as well as the maximum α_p^∞ of the $z(\alpha)$ function, can be used to guide the choice of a kinetic model. Both α_M and α_p^∞ parameters are especially useful in this respect. Their combination allows the determination of the most suitable kinetic model, as shown by the scheme in Fig. 4. As we can see, the empirical $SB(m, n)$ model gives the best description of TA data if $\alpha_p^\infty \neq 0.632$ and $\alpha_M \in (0, \alpha_p)$.

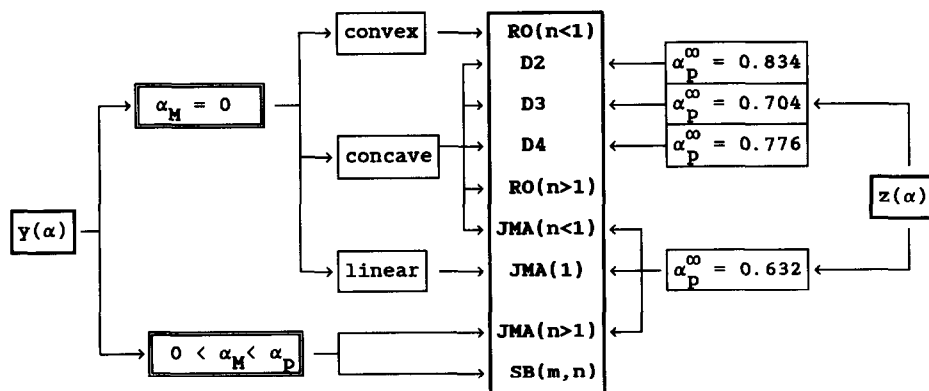

Fig. 4. Schematic diagram of the kinetic model determination.

According to our experience, these conditions are fulfilled for some solid state processes [10,11].

Calculation of the kinetic exponents

Once the kinetic model has been determined, the kinetic exponents, n (or m), can be calculated for the RO(n), JMA(n) or SB(m, n) models. The calculation method depends on the kinetic model and is described below.

RO(n) model

The kinetic exponent $n \neq 0$ for this model can be calculated iteratively using the equation

$$\alpha_p = 1 - \left[1 + \frac{1-n}{n} x_p \pi(x_p) \right]^{1/(n-1)} \tag{8}$$

This equation is obtained from eqn. (A4); it was derived originally by Gorbachev [12] for $\pi(x_p) = 1/(x_p + 2)$.

JMA(n) model

If the $y(\alpha)$ function has a maximum at $\alpha_M \in (0, \alpha_p)$, i.e. for $n > 1$, then the kinetic exponent n is calculated using eqn. (A13), rewritten in a somewhat different form as

$$n = \frac{1}{1 + \ln(1 - \alpha_M)} \tag{9}$$

If the $y(\alpha)$ function decreases steadily, i.e. $n \leq 1$, then the parameter n can be calculated by the Šatava method [13]:

$$\ln[-\ln(1 - \alpha)] = \text{constant} - nE/RT \tag{10}$$

i.e. from the slope of the plot of $\ln[-\ln(1 - \alpha)]$ versus $1/T$. An alternative method of calculation is based on the following equation (obtained from eqn. (A4)):

$$n = \frac{1 - x_p \pi(x_p)}{\ln(1 - \alpha_p) + 1} \tag{11}$$

It is known that the Šatava method gives slightly higher values for the parameter n . However, eqn. (11) gives lower ones. From our experience it seems that an average of these two values is a good approximation of the kinetic exponent.

SB(m, n) model

The kinetic parameter ratio $p = m/n$ is calculated using eqn. (A14), rewritten as

$$p = \alpha_M / (1 - \alpha_M) \tag{12}$$

Equation (1) can be rewritten in the form

$$\ln[(d\alpha/dt) e^x] = \ln A + n \ln[\alpha^p(1 - \alpha)] \quad (13)$$

The kinetic parameter n corresponds to the slope of the linear dependence $\ln[(d\alpha/dt) e^x]$ versus $\ln[\alpha^p(1 - \alpha)]$ for $\alpha \in (0.2, 0.8)$. Then the second kinetic exponent is $m = pn$.

Calculation of the pre-exponential factor

Knowing the value of the activation energy and the kinetic model, the pre-exponential factor is calculated using the equation [9]

$$A = - \frac{\beta x_p}{Tf'(\alpha_p)} \exp x_p \quad (14)$$

SOFTWARE FOR KINETIC ANALYSIS

It is rather surprising that the mutual correlation of kinetic parameters, as well as the apparent kinetic models, is very often ignored even in commercially available kinetics software. This is why a new software package, TA-system, was developed, based on the method of kinetic analysis of TA data described above.

TA-system runs under the MS DOS operating system on any IBM or compatible computer with at least 512 kB RAM and EGA or VGA graphics card. The system is very simple to use and it features flexible and interactive graphics capabilities which will present the results in an optimal way as required by the user. Both data and graphs can be exported into most graphical and spreadsheet software packages.

The software package includes programs to calculate the activation energy from several sets of kinetic data at various heating rates. This activation energy value is used by another program to calculate both the $y(\alpha)$ and $z(\alpha)$ functions. The shape of these functions enables the most probable kinetic model to be determined. Then the pre-exponential factors and kinetic exponents are calculated. This procedure is repeated for all heating rates. Therefore we obtain several sets of kinetic parameters corresponding to various heating rates. If the mechanism of the process does not change during the TA experiment, it would seem reasonable to expect that it will be possible to find the same kinetic parameters for different heating rates. The consistency of the kinetic model determined can also be assessed by comparing both experimental and calculated TA curves. Estimated kinetic parameters allow the calculation of isothermal α vs. t diagrams in order to predict the behaviour of the studied system under isothermal conditions.

CONCLUSION

It has been shown that both the activation energy and the pre-exponential factor are mutually correlated. As a consequence of this correlation, any TA curve can be described by an apparent kinetic model, instead of by the appropriate one, for a certain value of apparent activation energy. Therefore the kinetic analysis of TA data cannot be successful unless the true value of the activation energy is known.

Taking into account these facts, a new method for the kinetic analysis of TA data has been proposed. This method allows the determination of the most suitable kinetic model and the calculation of meaningful kinetic parameters for the general kinetic equation.

REFERENCES

- 1 J. Šesták, *Thermophysical Properties of Solids, Their Measurements and Theoretical Analysis*, Elsevier, Amsterdam, 1984.
- 2 J. Málek, J.M. Criado, J. Šesták and J. Militký, *Thermochim. Acta*, 153 (1989) 429.
- 3 N. Koga, J. Šesták and J. Málek, *Thermochim. Acta*, 188 (1991) 333.
- 4 J.M. Criado, D. Dollimore and G.R. Heal, *Thermochim. Acta*, 54 (1982) 159.
- 5 H.E. Kissinger, *Anal. Chem.*, 29 (1957) 1702.
- 6 T. Ozawa, *J. Therm. Anal.*, 2 (1979) 301.
- 7 E.S. Freeman and B. Carroll, *J. Phys. Chem.*, 62 (1958) 394.
- 8 J.M. Criado, J. Málek and A. Ortega, *Thermochim. Acta*, 147 (1989) 377.
- 9 J. Málek, *Thermochim. Acta*, 138 (1989) 337.
- 10 J. Málek and V. Smrčka, *Thermochim. Acta*, 186 (1991) 153.
- 11 J. Málek, *J. Non-Cryst. Solids*, 107 (1989) 323.
- 12 V.M. Gorbachev, *J. Therm. Anal.*, 27 (1983) 151.
- 13 V. Šatava, *Thermochim. Acta*, 2 (1971) 423.
- 14 G.I. Senum and R.T. Yang, *J. Therm. Anal.*, 11 (1977) 445.
- 15 J. Málek and J.M. Criado, *Thermochim. Acta*, 164 (1990) 199.

APPENDIX

The integral kinetic equation

If the temperature rises at a constant rate β then, after integration of eqn. (1)

$$g(\alpha) = \int_0^\alpha \frac{d\alpha}{f(\alpha)} = \frac{AE}{\beta R} \exp^{-x} \left[\frac{\pi(x)}{x} \right] \quad (\text{A1})$$

where $\pi(x)$ is an approximation of the temperature integral [1]. There are many approximate expressions of the $\pi(x)$ function in the literature. According to our experience, the rational expression of Senum and Yang [14] is sufficient

$$\pi(x) = \frac{x^3 + 18x^2 + 88x + 96}{x^4 + 20x^3 + 120x^2 + 240x + 120} \quad (\text{A2})$$

The condition for the maximum of the TA curve

Differentiating eqn. (1) with respect to time, the following equation is obtained [15]:

$$d^2\alpha/dt^2 = \left[\frac{\beta}{T\pi(x)} \right]^2 f(\alpha)g(\alpha)[f'(\alpha)g(\alpha) + x\pi(x)] \quad (\text{A3})$$

The condition for the maximum of the TA curve is obtained by setting eqn. (A3) equal to zero:

$$-f'(\alpha_p)g(\alpha_p) = x_p\pi(x_p) \quad (\text{A4})$$

Correlation of the kinetic parameters

Substitution of eqn. (A1) into eqn. (A4) gives

$$-f'(\alpha_p)A e^{-x_p} = \frac{\beta R x_p^2}{E} \quad (\text{A5})$$

which can be rewritten after converting it to a logarithmic form

$$\ln A = a + bE \quad (\text{A6})$$

where $b = 1/RT_p$ and $a = \ln[-\beta x_p/T_p f'(\alpha_p)]$.

The maximum of the $z(\alpha)$ function

An alternative expression for the reaction rate is obtained by combining eqns. (1) and (A1):

$$d\alpha/dt = \left[\frac{\beta}{T\pi(x)} \right] f(\alpha)g(\alpha) \quad (\text{A7})$$

After a rearrangement of eqn. (A7) the following equation can be written for $z(\alpha)$:

$$z(\alpha) = \frac{\pi(x)(d\alpha/dt)T}{\beta} = f(\alpha)g(\alpha) \quad (\text{A8})$$

Differentiating eqn. (A8) with respect to α , we obtain

$$z'(\alpha) = f'(\alpha)g(\alpha) + 1 \quad (\text{A9})$$

By setting eqn. (A9) equal to zero, we obtain eqn. (A10) which must be fulfilled by α_p^∞ at the maximum of $z(\alpha)$:

$$-f'(\alpha_p^\infty)g(\alpha_p^\infty) = 1 \quad (\text{A10})$$

An identical result is obtained from eqn. (A4) when x_p is infinite because in this case

$$\lim_{x_p \rightarrow \infty} [x_p \pi(x_p)] = 1 \quad (\text{A11})$$

Hence the value of α_p^∞ also corresponds to the maximum of a hypothetical DSC or DTA peak for $x_p \rightarrow \infty$.

The maximum of the $y(\alpha)$ function

Comparing eqns. (1) and (6) the function $y(\alpha)$ can be expressed as follows:

$$y(\alpha) = Af(\alpha) \quad (\text{A12})$$

Therefore the condition for the maximum of the $y(\alpha)$ function can be written as $f'(\alpha) = 0$. Analysing this condition, we can find that the D2, D3, D4 and RO(n) kinetic models have a maximum at $\alpha_M = 0$. It can also be shown that there is a maximum of the $y(\alpha)$ function $0 < \alpha_M < \alpha_p$ for both the JMA(n) and SB(m, n) models which depends on the value of the kinetic exponents. The condition for maximum of the JMA($n > 1$) model is given by the equation

$$\alpha_M = 1 - \exp\left(\frac{1-n}{n}\right) \quad (\text{A13})$$

Similarly, the condition for a maximum of the SB(m, n) model is expressed

$$\alpha_M = \frac{m}{m+n} \quad (\text{A14})$$